

## ELB-25-210-ES

200A 25kV Class Loadbreak Elbow with Integral Jacket Seal for Copper Tape (CT) and Jacketed Concentric Neutral (JCN) cables

### Product Installation Instructions

#### Safety Instructions

**⚠ DANGER** *When installing electrical power system accessories, failure to follow applicable personal safety requirements and written installation instructions could result in fire or explosion and serious or fatal injuries.*

**⚠ DANGER** *As TE has no control over field conditions which influence product installation, it is understood that the user must take this into account and apply his own experience and expertise when installing product.*

**⚠ DANGER** *Working around energized high-voltage systems may cause serious injury or death. Installation should be performed by personnel familiar with good safety practice in handling high-voltage electrical equipment. De-energize and ground all electrical systems before installing product.*

**⚠ DANGER** *Power distribution and transmission products must be properly selected for the intended application. It must be installed and serviced by competent personnel who have been trained and understand proper safety procedures. These instructions are written for such personnel and are not a substitute for adequate training and experience in safety procedures.*

**⚠ CAUTION** *Read and understand the contents of these instructions before installation and follow all locally approved procedures and safety practices before installing or operating this equipment*

**⚠ CAUTION** *These instructions cannot cover all details or variations in the equipment, procedures, or processes described, nor provide directions for meeting every possible contingency during installation, operation, or maintenance. When additional information is desired to satisfy a problem not covered sufficiently for the user's purpose, please contact your TE sales representative. These instructions are not intended to supersede or replace existing safety and operating procedures.*

**NOTICE** *Upon receipt of a product, inspect it thoroughly for damage and loss of parts incurred during shipment. If damage or loss is discovered, file a claim with the carrier immediately or contact your TE representative.*

#### Suggested Installation Equipment (not supplied with kit)

- Cable preparation tools

#### General Information

TE's ELB-25-210 elbows are designed to terminate underground cables to high-voltage apparatus such as transformers and switchgear that are equipped with load break bushings. They are fully shielded and fully submersible and are designed in accordance to IEEE Standard 386 (latest revision). Loadbreak elbows are designed for use with standard hot stick tools, which allow a load make/break operation with a physical disconnect.

#### Customer Service

For 24 hour customer service, call 800-327-6996.

## Installation Instructions

### 1. Check kit

Check kit to insure proper fit with the cable.  
 Sizes shown in table 1.

**Table 1:** 200amp 25kV Loadbreak Elbow Size Reference Chart (Integral Seal)

Cable Size(AWG/Kcmil)		Insulation Diameter in(mm)	25 kV - 260 mil (100%) Insulation
STR/COMPR	COMPT/SOL		
#1	1/0	0.720"-0.985"(18.3-25.0mm)	ELB-25-210B1-ES
1/0	2/0	0.720"-0.985"(18.3-25.0mm)	ELB-25-210B10-ES
2/0	3/0	0.920"-1.185"(23.4-30.1mm)	ELB-25-210C20-ES
3/0	4/0	0.920"-1.185"(23.4-30.1mm)	ELB-25-210C30-ES
4/0	250	1.040"-1.304"(26.4-33.1mm)	ELB-25-210D40-ES

Choose the cable type (Choice 1 below or Choice 2: Copper Tape Shield on page 7) and follow the directions given.

**Choice 1: Jacket Concentric Neutral or Unjacketed Concentric Neutral cable**

### 2. Position cable

For illustrative purposes, JCN is being shown to the right.

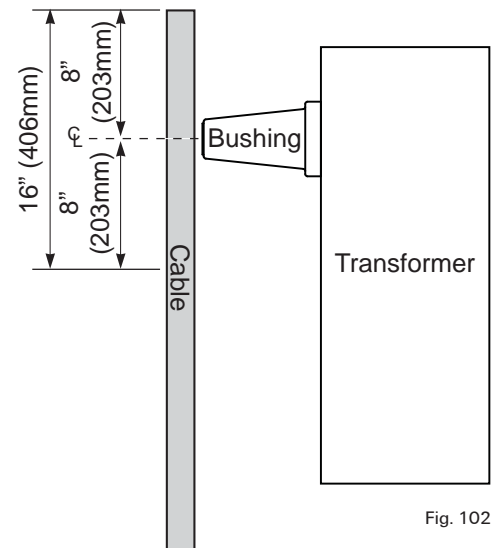

Fig. 102

### 3. Clean and degrease

Clean and degrease the end of the cable jacket for 24" with solvent.

#### 4. Cut back cable jacket

Position the cable with 8" (203mm) overlap to the bushing center. Mark the cable jacket 8" (203mm) below the bushing center

Position the cable with enough slack to allow movement of elbow to insulated parking bushing.

Remove 16" (406mm) of cable jacket to expose neutral wires.

**NOTICE** *If using an elbow sealing kit - review the instructions before starting the elbow cable prep to avoid redundant steps.*

For illustrative purposes, JCN is being shown to the right.

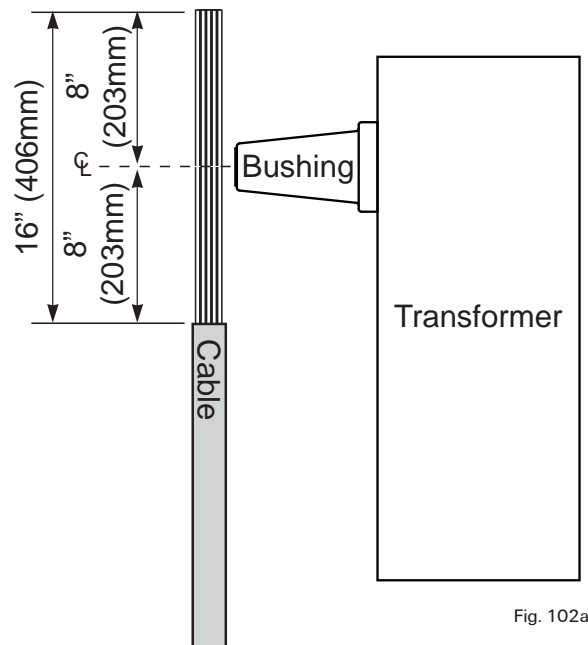

Fig. 102a

#### 5. Prepare cable

Apply 2 layers of gray mastic on the cleaned, cable jacket cutback for a minimum of 1" (25mm).

Carefully bend neutral wires back onto the cable jacket. Temporarily secure wires with PVC tape.

Measure 8" (203mm) up from the cable jacket cut back and cut off excess cable. Make a clean square cut.

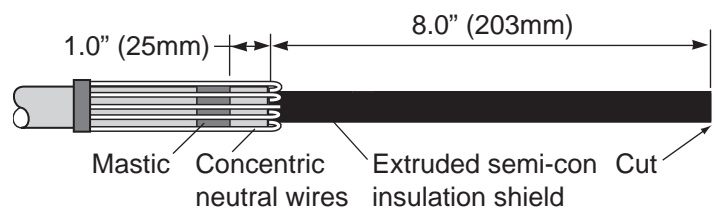

Fig. 103

#### 6. Remove semi-con

Remove semi-con as shown. It is very important to make a square cut of the semi-con, without nicking the insulation.

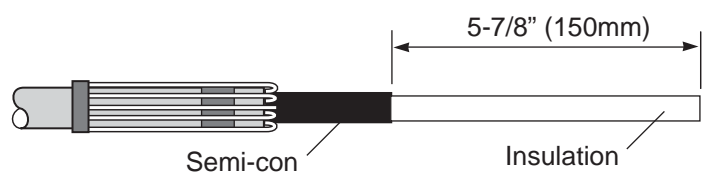

Fig. 108c

#### 7. Remove insulation

Remove insulation exposing conductor 2-1/8" (54mm).

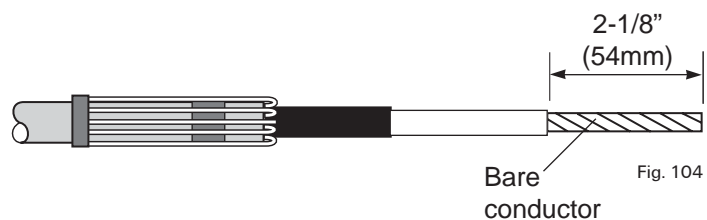

Fig. 104

### 8. Chamfer and clean insulation

Remove sharp edge of insulation by chamfering the end of the cable insulation at a 15° angle, approximately 1/8" back.

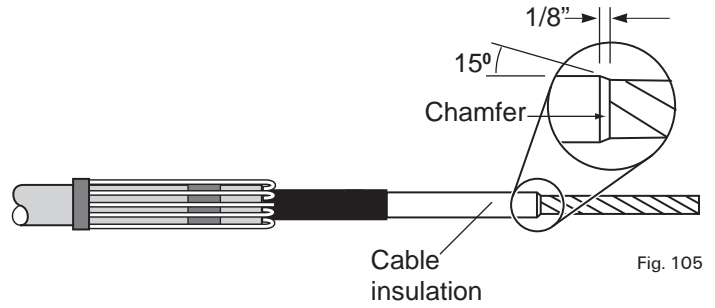

Fig. 105

### 9. Install connector

Prepare aluminum conductor by wire brushing just prior to insertion into connector. Remove protective cap and fully insert conductor into compression lug. Before crimping the lug, confirm that the dimension between semi-con cutback to the end of lug is approximately 6-7/8" (174mm). Crimp the lug following the instructions supplied. Wipe excess inhibitor from connector.



Fig. 108

After installation, use abrasive strip to deburr lug if necessary.

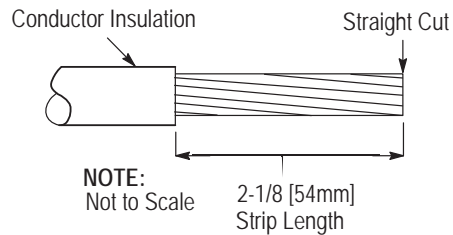
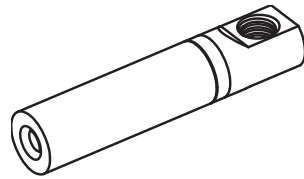

CATALOG NO. PART NO.	CONDUCTOR SIZE (ALUMINUM OR COPPER)			DIE CROSS REFERENCE						
				BURNDY			KEARNEY		T&B	CSA†
	STD STR/ COMPR	COMPACT	SOLID	MD6, 7	Y35, Y39	Y45†	O	H1, H2	TBM15 TBM14M	DIE NO.
BCM2E-6 1710979-1	6	5	5	W243 (3) WBG (3) BG (5)	U243 (2) UBG (3) U27RT (3)	U243 (2) UBG (3) U27RT (3)	5/8 (5) Nose	9/16 (3) or 5/2 (2)	50 (3)	22(2)
BCM2E-5 1710979-2	5	4	4							
BCM2E-4 1710979-3	4	3	3							
BCM2E-3 1710979-4	3	2	2							
BCM2E-2 1710979-5	2	1	1							
BCM2E-1 1710979-6	1	1/0	1/0							
BCM2E1/0 1710979-7	1/0	2/0	2/0							
BCM2E-2/0 1710979-8	2/0	3/0	3/0	W247 (4)	U29RT (3) U27ART (3)	U29RT (3) U27ART (3)	747 (3)	747 (2)	62 (2)	---
BCM2E-3/0 1710979-9	3/0	4/0	4/0							
BCM2E-4/0 1-1710979-0	4/0	250	---							

† Tool Y45 requires the use of adapter PT6515 when U-type dies are to be used. ‡Overlap crimps. BURNDY, KEARNEY, and T&B are trademarks of their respective owners.

## 10. Apply mastic

Apply two layers of gray mastic over the folded back neutral wires and previously applied mastic near the jacket cutback.

Also apply two layers of mastic 1/2" onto cable semi-con, forming a jacket seal. Wrap the cable and mastic with one half lapped layer of PVC tape(not included).

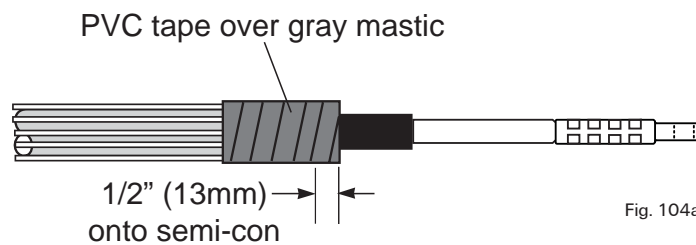

Fig. 104a

## 11. Install elbow

Thoroughly clean the insulation with a solvent dampened cloth, wiping from the connector toward the semi-con. Lubricate the exposed insulation with the provided silicone grease, always working toward the cable semi-con.

Push the elbow body onto the lubricated cable with a slight twisting motion until the connector eye is aligned with the elbow bushing interface.

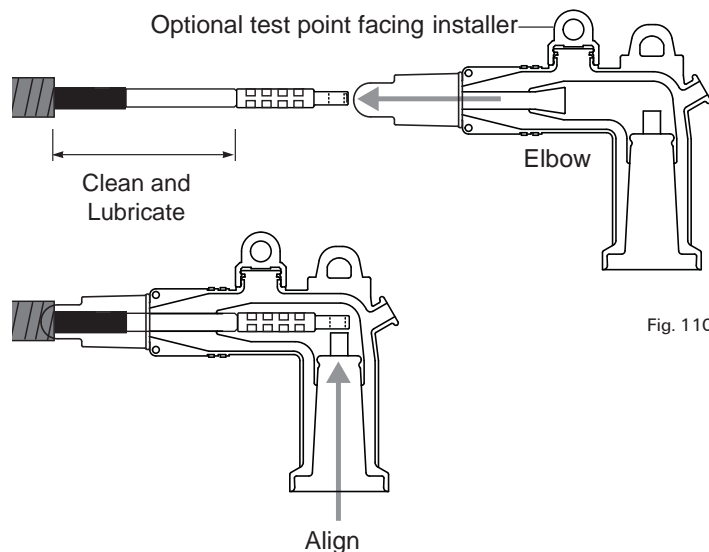

Fig. 110

## 12. Install loadbreak probe

Make sure the gap between the cable jacket cutback and the end of the elbow does not exceed 2" (50mm).

By hand, carefully insert the threaded end of the loadbreak probe into the interface opening and thread the probe into the copper top connector until hand tight. Use the provided torque tool to properly tighten the probe by inserting it into the hole in the probe, turning clockwise. Proper torque is reached when the tool bends 180 degrees.

**NOTICE** *If a different installation tool is used, it must apply a torque of 8. 1-10 lbf-ft (11.0-13.5 N-m).*

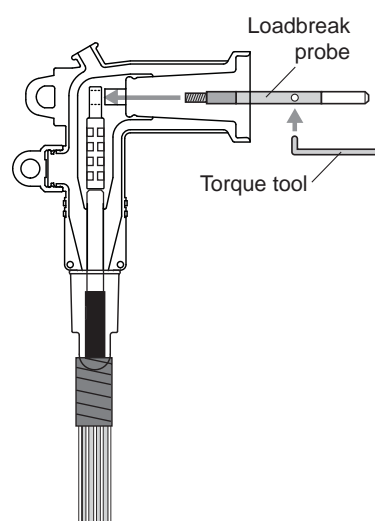

Fig. 110a

### 13. Install jacket seal

Grasping the tabs of the Integral jacket seal, pull downward so jacket seal unfolds over the PVC tape covered mastic.

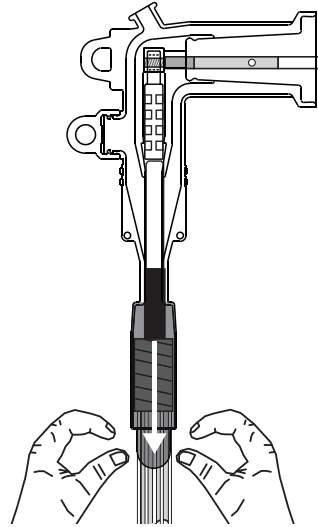

Fig. 110aa

---

### 14. Ground system

Connect the grounding eye of the elbow with a minimum #14 AWG copper drain wire. Connect drain wire to cable's concentric neutrals. Connect neutral wires to system ground.

**Installation is complete.**

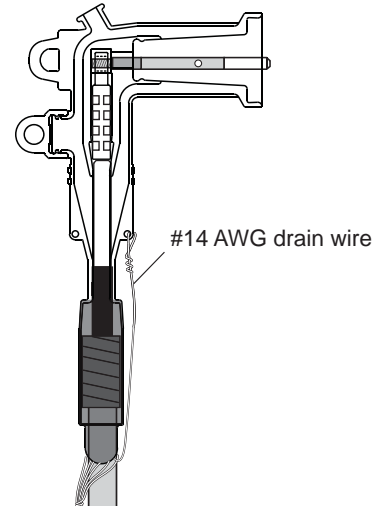
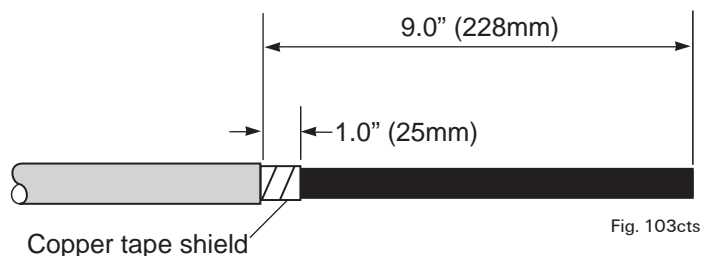

Fig. 110b

## Choice 2: Copper Tape Shield

### 13. Prepare cable

Remove outer jacket 9.0" (228mm) from end of cable. Remove copper tape shield to 1" (25mm) from jacket cutback.



### 14. Remove semi-con

Remove semi-con as shown.

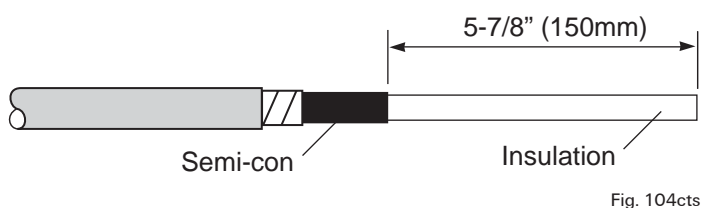

### 15. Remove insulation

Remove insulation exposing conductor 2-1/8" (54mm).

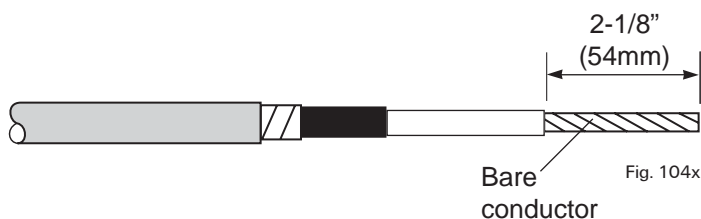

### 16. Chamfer and clean insulation

Remove sharp edge of insulation by chamfering the end of the cable insulation at a 15° angle, approximately 1/8" back.

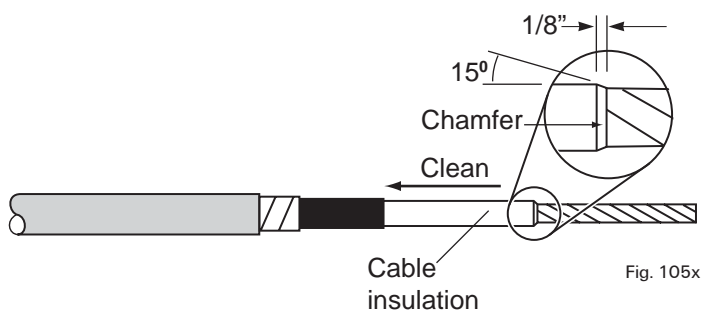

### 17. Install connector

See crimping chart on page 4. Prepare aluminum conductor by wire brushing just prior to insertion into connector. Remove protective cap and fully insert conductor into compression lug. Before crimping the lug, confirm that the dimension between semi-con cutback to the end of lug is approximately 6-7/8" (174mm). Crimp the lug following the instructions supplied. Wipe excess inhibitor from connector.

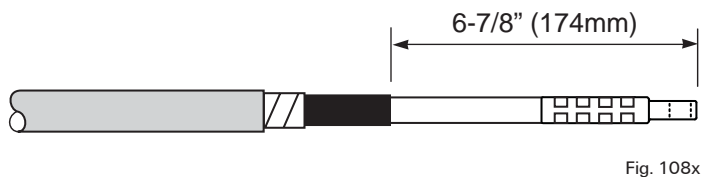

After installation, use abrasive strip to deburr lug if necessary.

## 18. Install ground braid

(1) Lay the ground braid on the cable with the solder block aligned with the jacket cutback and the short end of the braid over the exposed copper tape shield.

(2) Attach the braid to the tape shield by placing two wraps of the spring clamp over the braid.

(3) Fold the short end of the braid back over the spring clamp wraps as shown. Continue to wrap the remaining clamp over the braid. Tighten clamp by twisting it in the direction it is wrapped and secure with the copper foil tape provided.

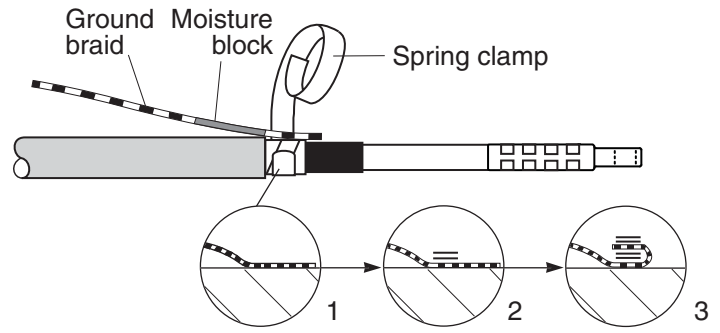

Fig. 110cts

## 19. Install mastic and PVC tape

Clean cable jacket to 6" from jacket cutback. Install 2 wraps of gray mastic onto jacket at the copper braid solder block. Press the solder block into the mastic. Install remaining mastic over the braid and spring clamp sealing the jacket cutback. Wrap the mastic with 2 layers of PVC tape (not included).

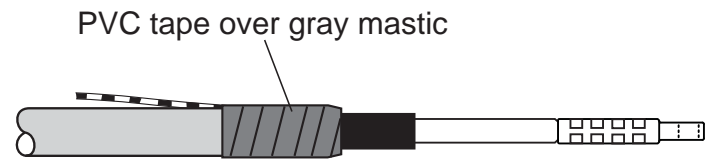

Fig. 104ab

## 20. Install elbow

Thoroughly clean the insulation with a solvent dampened cloth, wiping from the connector toward the semi-con. Ensure that all traces of conductive residue are removed. Lubricate the exposed insulation with the provided silicone grease, always working toward the cable semi-con.

Push the elbow body onto the lubricated cable with a slight twisting motion until the connector eye is aligned with the elbow bushing interface.

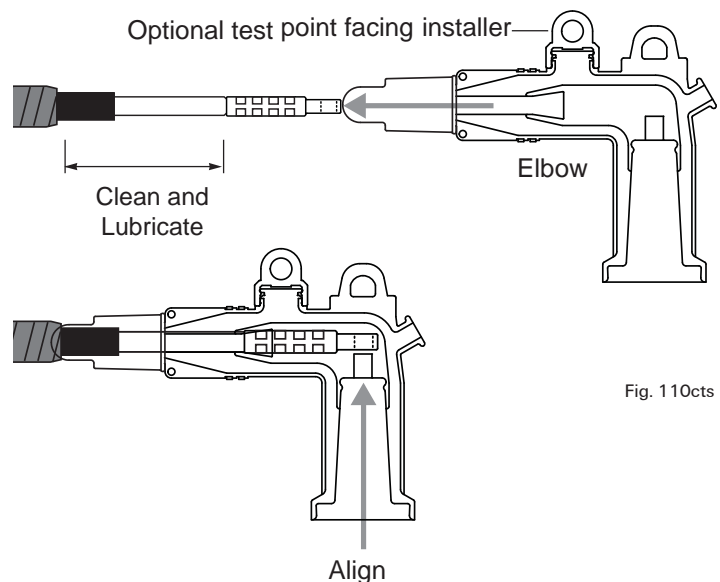

Fig. 110cts



## 21. Install Loadbreak Probe

Make sure the gap between the cable jacket cutback and the end of the elbow does not exceed 2" (50mm).

By hand, carefully insert the threaded end of the loadbreak probe into the interface opening and thread the probe into the copper top connector until hand tight. Use the provided torque tool to properly tighten the probe by inserting it into the hole in the probe, turning clockwise. Proper torque is reached when the tool bends 180 degrees. Install Loadbreak Probe

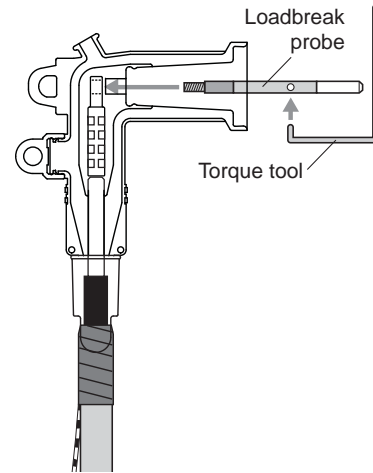

Fig. 110acts

**NOTICE** If a different installation tool is used, it must apply a torque of 8.1-10 lbf-ft (11.0-13.5 N-m).

## 22. Install jacket seal

Grasping the tabs of the Integral jacket seal, pull downward so jacket seal unfolds over the PVC tape covered mastic.

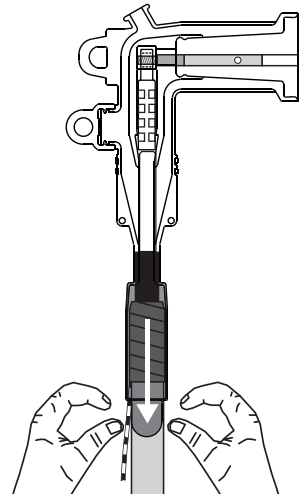

Fig. 110aaa

## 23. Ground system

Connect the grounding eye of the elbow with a minimum #14 AWG copper drain wire. Connect drain wire to grounding braid and connect the ground braid to system ground.

**Installation is complete.**

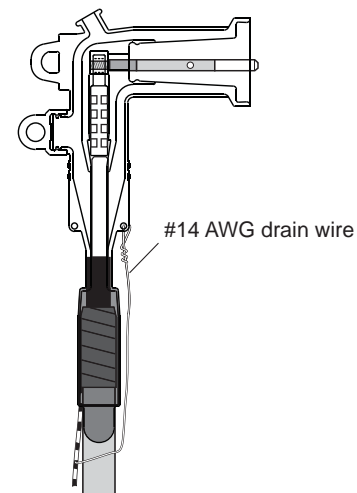

Fig. 110bcts

The Information contained in these installation instructions is for use only by installers trained to make electrical power installations and is intended to describe the correct method of installation for this product. However, TE has no control over the field conditions which influence product installation. It is the user's responsibility to determine the suitability of the installation method in the user's field conditions. TE's only obligations are those in TE's standard Conditions of Sale for this product and in no case will TE be liable for any other incidental, indirect or consequential damages arising from the use or misuse of the products.

Raychem, TE Connectivity and TE connectivity (logo) are trademarks. Other trademarks used are the property of their respective owners. Copyright 2013 Tyco Electronics Corporation, a TE Connectivity Ltd. Company. All Rights Reserved.

