

# ADVANCED DISTRIBUTION GRID MONITORING SYSTEM

## GridView™ Deadbreak Elbow Adaptor Medium Voltage Sensor System

### Product Overview:

- 4kV to 15kV Submersion rated, 95kV BIL, 60 Hz
- Voltage Sensing Modular “Deadbreak” Elbow Adapter
- Sensing Voltage: 4 kV to 15 kV
- Transients: 10 dB (10x steady state condition)
- Harmonics: Measurements to 50th Voltage Harmonic
- 3/8-16 UNC Mount Standard- 200A
- Approximate weight: 5 lbs. (5.4 kg)

### Application:

The GridView™ Deadbreak Elbow Adaptor Sensor, utilizes a 100% “all optical” measurement platform for unparalleled accuracy and precision of voltage readings, across multiple voltage classes. Specifically designed for installation in standard 200A or 600A Deadbreak elbows. All signals from the sensor are connected via optical fiber connections to a “plug & play” (m410) Modular Optical Sensor Platform, that is fully ruggedized and scalable.

### Features:

The GridView™ Deadbreak Elbow Adaptor Sensor, is a direct replacement for standard resistive voltage divider sensors and capacitive coupler sensors. Because of the “all optical” sensor design, there are no conductive materials used for the measurement of both voltage as well as the transmission of the optical signals. The insulator body is cast in hydrophobic cycloaliphatic epoxy (HCEP) using a state of the art injection molding process. HCEP construction provides superior arc track, ozone, and ultraviolet-resistive properties while maintaining physical strength. The hydrophobic surface properties of HCEP, ensure highly reliable performance in wet or humid conditions. All calibration and performance settings are stored in the ruggedized modular electronics enclosure located at the base of the optical cable. When integrated with the (m410) Modular Optical Sensor Processor, this provides for a “highly accurate” as well as “low cost” precision solution for distribution grid monitoring and control. Features include:

#### All optical Solution for Voltage Measurements:

- R<sup>e</sup>120: One SKU for 200A “Deadbreak” Elbow Voltage Classes
- R<sup>e</sup>160: One SKU for 600A “Deadbreak” Elbow Voltage Classes
- Designed for harsh operational environments
- Calibration and offsets are contained within the R<sup>e</sup>120 Sensor

#### Benefits of HCEP:

- Enhanced water shedding properties
- Reduced contamination-related leakage
- Improved product quality and reliability
- Improved UV protection
- Results in a more consistent and reliable product

### Installation:

The GridView™ Deadbreak Elbow Adaptor Sensor installs directly inside standard 200A or 600A “Deadbreak elbows” via a 3/8-16 UNC conduction rod.

### Performance:

The GridView™ Deadbreak Elbow Adaptor Sensor provides both high accuracy and precision that remains constant regardless of applied voltage. Average accuracy is  $\pm 0.15\%$  from 1% of nominal operational temperatures of 21°C (70°F) and  $\pm 0.5\%$  within a temperature range of -30°C(-22°F) to 70°C(158°F).

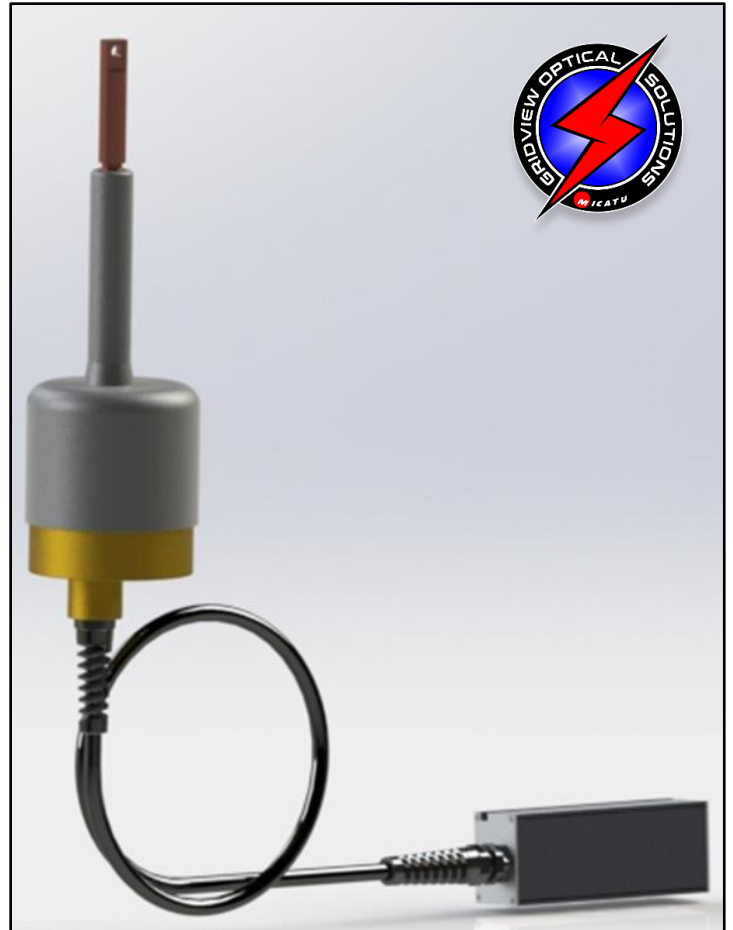

### Specifications: GridView™ R<sup>e</sup>120 Sensor

#### Sensor:

- Insulator Body rating 200A, 20ft/(6m) Cable Length
- 3/8-16 UNC Mount Standard - 200A
- Submersion Rated to 25ft (Seven Days)
- Transients: 10 dB (10x steady state condition) minimum
- Harmonics: Measurements to 50th Harmonic
- Accuracy: +/- 0.5% Voltage & Current
- Long term stability +/- 0.25%

#### Environmental:

- Operational: -22°F to 158°F (-30°C to 70°C)
- Relative Humidity: 5% to 95%

#### Certifications:

- Acid Atmosphere: MIL-STD-810G, Method 518.1
- Salt Fog: MIL-STD-810G, Method 509.5.
- Temperature Shock: MIL-STD-810G, Method 503.5
- Vibration: MIL-STD-810G, Method 514.6, 514.6C-4
- BIL: 95kV, AC Withstand: 1 minute, 34kV
- Partial Discharge Per IEEE Std. 4

#### Typical Included Components:

- Three GridView™ R<sup>i</sup>125 Sensors
- Suggested Insulation Guide

#### Test Reports:

Test reports are stored electronically and can be e-mailed in various formats at the time of shipment.

**Unit Dimensions:**

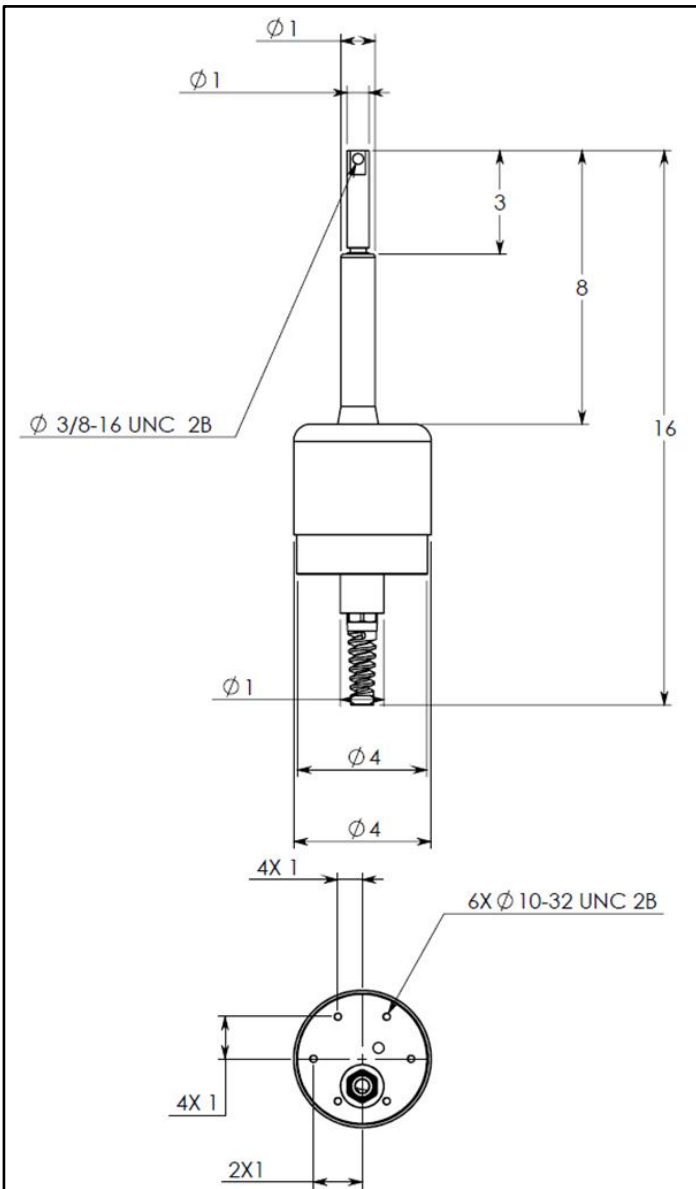

SKU: R<sup>o</sup>120  
 Additional styles available. Contact your Eaton's GridAdvisor sales representative.

**For more information please contact:**  
[Eaton's GridAdvisor](#)

**GridView™ Voltage & Current Configurator:**

GridView Voltage & Current Sensor Ordering Configurator		<input type="text"/>	<input type="text"/>	<input type="text"/>
<b>Sensor Configuration:</b>				
GridView Overhead Sensor	R <sup>o</sup>	}	}	}
GridView Standoff Insulator Sensor	R <sup>i</sup>			
GridView Elbow Sensor	R <sup>e</sup>			
<b>Sensor Type Configuration</b>				
Voltage Only Sensor	1	}	}	}
Combination Sensor (Voltage & Current)	2			
Current Only Sensor	3			
<b>Sensor Insulating Rating</b>				
15kV Insulator Rating	15 (R <sup>i</sup> Only)	}	}	}
35kV Insulator Rating	35 (R <sup>i</sup> & R <sup>o</sup> Only)			
Standard 200A "Deadbreak" Elbow	20 (R <sup>e</sup> Only)			
Standard 600A "Deadbreak" Elbow	60 (R <sup>e</sup> Only)			

**Electronic Scannable QRC Formats:**

Vcard Information and digital PDF of the GridView™ Brochure



Note: The information contained in this document is for general information purposes only. While Eaton's GridAdvisor strives to keep the information up to date and correct, it makes no representations or warranties of any kind, express or implied, about the completeness, accuracy, reliability, suitability or availability with respect to the information, products, services, or related graphics contained in the document for any purpose. Any reliance placed on such information is therefore strictly at your own risk. Eaton's GridAdvisor reserves the right to discontinue any product or service at any time. Copyrighted 2020 Eaton's GridAdvisor. All rights reserved.