

ADVANCED DISTRIBUTION GRID MONITORING SYSTEM

GridView™ Standoff Insulator Medium Voltage Sensor System

Product Overview:

- 4kV to 25kV Outdoor rated, 125kV BIL, 60 Hz
- Voltage Sensing Standoff Insulator
- Sensing Voltage: 4 kV to 25 kV
- Transients: 10 dB (10x steady state condition)
- Harmonics: Measurements to 50th Voltage Harmonic
- 4X 1/2-13 Mounting Nuts Top and Bottom
- Approximate weight: 12 lbs. (5.4 kg)

Application:

The GridView™ Standoff Insulator Voltage Sensor, utilizes a 100% “all optical” measurement platform for unparalleled accuracy and precision of voltage readings, across multiple voltage classes. Specifically designed for installation in masonry switchgear, air insulated switchgear (AIS) and for any phase to ground busbar measurements. All signals from the sensor are connected via optical fiber connections to a “plug & play” (m410), Modular Optical Sensor Platform, that is fully ruggedized and scalable.

Features:

The GridView™ Standoff Insulator Voltage Sensor is a direct replacement for standard resistive voltage divider sensors. Because of the “all optical” sensor design, there are no conductive materials used in the measurement of voltage as well as the transmission of the optical signals. The insulator body is cast in hydrophobic cycloaliphatic epoxy (HCEP) using a state of the art injection molding process. HCEP construction provides superior arc track, ozone, and ultraviolet-resistive properties while maintaining physical strength. The hydrophobic surface properties of HCEP ensure highly reliable performance in wet or humid conditions. All calibration and performance settings are stored in the ruggedized modular electronics enclosure at the base of the optical cable. When integrated with the (m410) Modular Optical Sensor Processor, this provides for a “highly accurate” as well as “low cost” precision solution for distribution grid monitoring and control. Features include:

All optical Solution for Voltage Measurements:

- **Rⁱ125**: One SKU for 4kV to 25kV Voltage Classes
- **Rⁱ135**: One SKU for 4kV to 35kV Voltage Classes
- Four 1/2-13 UNC mounts on top and bottom
- Calibration and offsets are contained within the Rⁱ125 Sensor

Benefits of HCEP:

- Enhanced water shedding properties
- Reduced contamination-related leakage
- Improved product quality and reliability
- Improved UV protection

Installation:

The GridView™ Standoff Insulator Voltage Sensor installs directly on the conductor wire using conduction grade, aluminum wire clamps or direct mounting to the busbar via eight- 1/3-13 UNC bolts. Additional, mounting options and sizes are available, please contact a Micatu sales representative

Performance:

The GridView™ Standoff Insulator Voltage Sensor provides both high accuracy and precision that remains constant regardless of applied voltage. Average accuracy is $\pm 0.15\%$ from 1% of nominal operational temperatures of 21°C (70°F) and $\pm 0.5\%$ within a temperature range of -30°C(-22°F) to 70°C(158°F).



Specifications: GridView™ Rⁱ125 Sensor

Sensor:

- Insulator Body rating 25kV, 20ft/(6m) Cable Length
- 4x 1/2-13 UNC Mounts (top and bottom)
- 1X 1/4-20 UNC Electrical Contact Mount (top)
- Transients: 10 dB (10x steady state condition) minimum
- Harmonics: Measurements to 50th Harmonic
- Accuracy: +/- 0.5% Voltage & Current
- Long term stability +/- 0.25%

Environmental:

- Operational: -22°F to 158°F (-30°C to 70°C)
- Relative Humidity: 5% to 95%

Certifications:

- Acid Atmosphere: MIL-STD-810G, Method 518.1
- Salt Fog: MIL-STD-810G, Method 509.5.
- Temperature Shock: MIL-STD-810G, Method 503.5
- Vibration: MIL-STD-810G, Method 514.6, 514.6C-4
- BIL: 125kV Full-Wave Lightning Impulse
- Partial Discharge Per IEEE Std. 4

Typical Included Components:

- Three GridView™ Rⁱ125 Sensors
- Suggested Insulation Guide

Test Reports:

Test reports are stored electronically and can be e-mailed in various formats at the time of shipment.

Unit Dimensions:

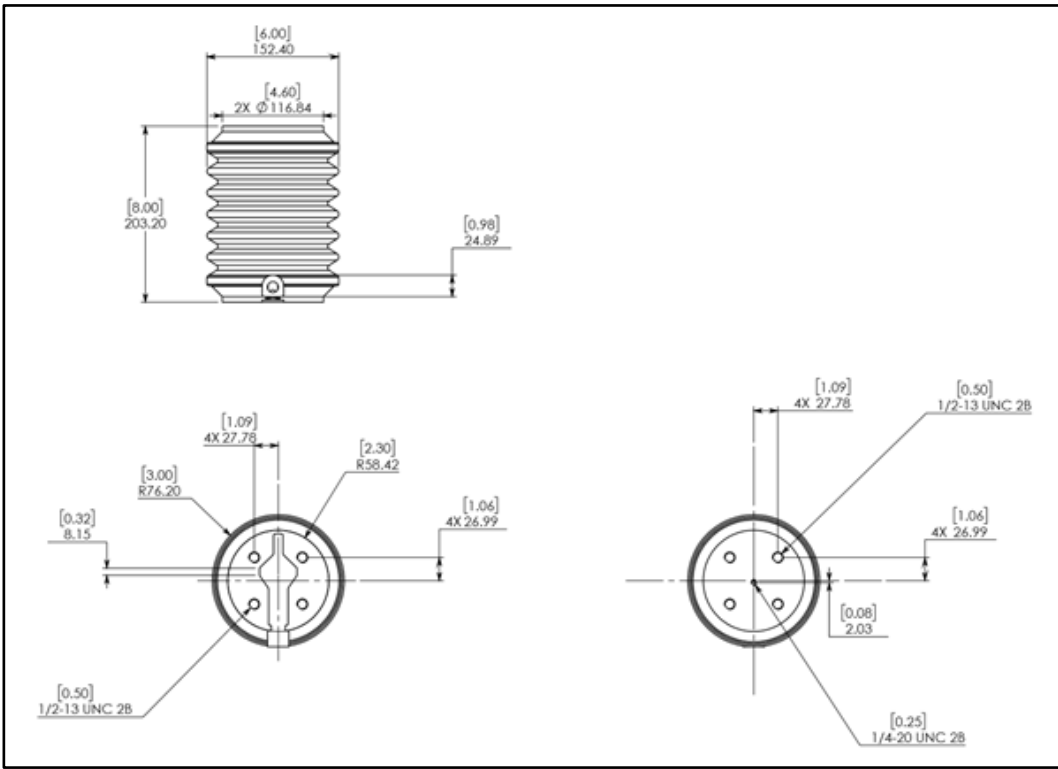

SKU: R¹125

Additional styles available. Contact your Micatu sales representative.

Electronic Scannable QRC Formats:

Vcard Information and digital PDF of the GridView™ Brochure

For more information please contact:
Eaton's GridAdvisor



GridView™ Voltage & Current Configurator:

GridView Voltage & Current Sensor Ordering Configurator		<input type="text"/>	<input type="text"/>	<input type="text"/>
Sensor Configuration:				
GridView Overhead Sensor	R ⁹	}	}	}
GridView Standoff Insulator Sensor	R ¹			
GridView Elbow Sensor	R ⁰			
Sensor Type Configuration				
Voltage Only Sensor	1	}	}	}
Combination Sensor (Voltage & Current)	2			
Current Only Sensor	3			
Sensor Insulating Rating				
15kV Insulator Rating	15 (R ¹ Only)	}	}	}
35kV Insulator Rating	35 (R ¹ & R ⁹ Only)			
Standard 200A "Deadbreak" Elbow	20 (R ⁰ Only)			
Standard 600A "Deadbreak" Elbow	60 (R ⁰ Only)			

Note: The information contained in this document is for general information purposes only. While Eaton's GridAdvisor strives to keep the information up to date and correct, it makes no representations or warranties of any kind, express or implied, about the completeness, accuracy, reliability, suitability or availability with respect to the information, products, services, or related graphics contained in the document for any purpose. Any reliance placed on such information is therefore strictly at your own risk. Eaton's GridAdvisor reserves the right to discontinue any product or service at any time. Copyrighted 2020 Eaton's GridAdvisor. All rights reserved.